



DATAMATION
systems
inc.

Technical Access Furniture



LAN Access Modular Command Center and LAN Lab Furniture: The Cost Effective Solution.

(Above) cabinets beneath the work surface provide 27" of vertical clearance for servers.

(Right) LAN lab furniture requires the flexibility to support an ever changing range of equipment configurations while providing access to systems analysts and engineers for testing and evaluation.

LAN Access Command Center modules provide unequalled flexibility, access and control in technology intensive applications. Servers up to 27" high are accommodated beneath the work surface, and for LAN Labs where a variety of equipment is constantly undergoing configuration testing and evaluation, work surfaces up to 4' deep are available with rubber bumper edges to protect both equipment and furniture.

And as your needs change and equipment requirements grow, our modular furniture is easily reconfigured or extended. Available in a range of durable laminate finishes, LAN Access Command Centers bring simplicity, design clarity and sensible costs to the organization of computer intensive environments.

A complete range of equipment storage, display and organization options include:

- Monitor bridges in single and dual level configurations with integrated keyboard storage and cable management
- Aluminum slatwall back with infinite options for monitor and organizer shelf placement
- Retractable keyboard supports with tilt and swivel control
- Pull-out tower shelves supported by extension slides
- Continuous cantilevered work surfaces for ease of movement between positions

The high quality of all LAN Access furniture is assured by our seven year limited warranty.

Choose From A Wide Range of LAN Access Components to Meet Your Specific Requirements

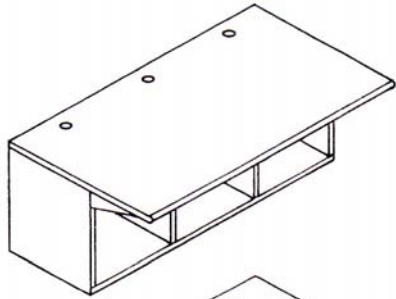

Consoles are available in widths of 24", 48" and 72" and work surface depths of 36", 42" and 48".

Consoles are 29 1/2" high with 27" vertical clearance inside cabinets. Cantilevered work surface includes cable grommets and ergonomic bumper edge.

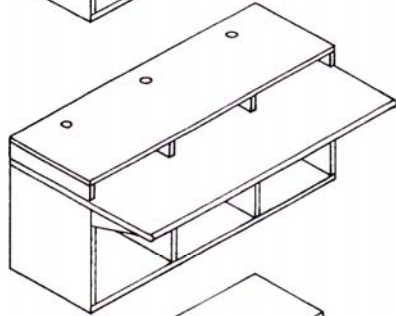

Monitor Platforms with keyboard storage are available in widths of 24", 48" and 72", and depths of 18", 24" and 30".

Platforms are 4" high with 3" vertical clearance for keyboard storage, and include cable grommets.

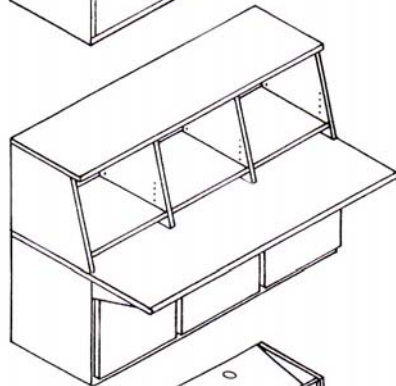

Enclosed Monitor Bridges are available in widths of 24", 48" and 72", and depths of 18", 24" and 30".

Monitor Bridge is 24" high, includes keyboard storage under an adjustable height shelf and up to 20" vertical clearance for monitors. Bridges have full backs with vents; shelves have cable grommets.

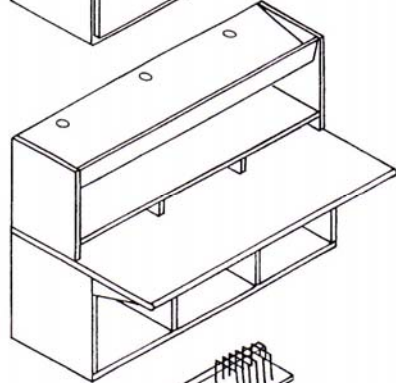

Dual Level Monitor Bridges are available in widths of 24", 48" and 72", and depths of 18", 24" and 30".

Bridge is 24" high, includes keyboard storage under the fixed bottom shelf and 16" vertical clearance for monitors under an angled top monitor shelf. Bridges have full backs with vents; shelves have cable grommets.

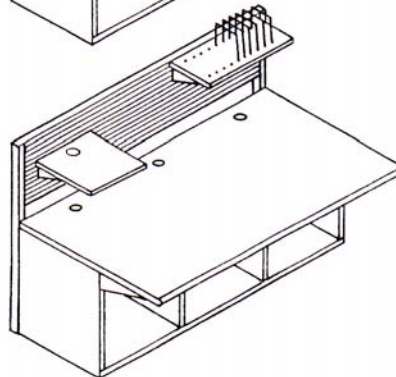

Slatwall support system is available in widths of 24", 48" and 72".

Slatwall is black powder coated structural aluminum, extends from 33 1/2" to 49 1/2" high and provides universal placement for monitor supports and organizers.

All LAN Access components are available made-to-measure for special applications.



For additional information please call **Cheryl Katzman** at **Datamation Systems**:
(201) 329-7200 or (973) 796-8468 FAX: (201) 329-7272

Datamation Systems, Inc., 125 Louis Street, South Hackensack, NJ 07606-1733
email: Datamation@pobox.com web: www.pc-security.com/caseworkDS

